



Model No. Quattro Diamond (Q600)
Model No. Quattro Platinum (E500)
Model No. Quattro Manual Movers



REMOTE CARAVAN MOVER
Electronics installation guide,
user information and troubleshooting

UK

Quick Start Guide

IT IS STRONGLY RECOMMENDED THAT THE ENTIRE MANUAL IS READ AND UNDERSTOOD BEFORE OPERATING YOUR MOVER, THIS ENSURES PROPER SETUP AND SAFE USE. THIS QUICK START GUIDE PAGE ACTS AS A QUICK POINT OF REFERENCE FOR THE REGULARLY USED FUNCTIONS OF THE HANDSET.

Power On

1. Turn caravan isolation key to the on position.
2. Press handset button Fig.1.C twice quickly.
3. When all icons are solid on the home screen, the mover is ready to operate.

Power Off

1. Press handset button Fig.1.C twice quickly
2. Turn caravan isolation key to the off position.

Engage Mover (Auto Mover Only)

1. Press and hold handset button Fig.1.C for three seconds to begin engaging, once completed the handset will return to the home screen automatically.

Disengage Mover (Auto Mover Only)

1. Press and hold handset button Fig.1.C for three seconds to begin disengaging, once completed the handset will return to the home screen automatically.

Manoeuvring

1. Move thumb stick Fig.1.B progressively in the direction of travel.
2. Press thumb stick Fig.1.C once to flip direction of travel if required.

Basic Troubleshooting - See page 8 for more info.

Handset not powering on (no information on display).

Replace handset batteries. Failing this, contact manufacturer.

Magnifying glass icon showing in bottom left corner of screen.

This indicates that the handset is searching for the control box and has not yet connected. Ensure the isolation key is switched on and the control box within the caravan is receiving power (LED lights on). If the handset does not pair within 10 seconds (Icon should change to smiling face), press thumb-stick button Fig.1.B two times to enter pairing mode and hold within 10cm of the box.

No LED lights showing on control unit within caravan.

This indicates a power issue. Ensure that the isolation key has been turned to the "on" position and that the battery is fully charged and functioning properly. Failing this, please contact manufacturer.

The handset pairing process has been followed and both the handset and control box are paired (home screen icons are now solid) but the system will still not operate.

Check the handset screen or control box within the caravan for an indication of the error code using page 8 in this manual as a guide.

The caravan will move for a short distance but then stops.

Check the handset screen or control box within the caravan for an indication of the error using page 8 in this manual as a guide. If the mover system moves for a short distance this is usually a power related issue (battery). Ensure that the battery is fully charged and is working properly.

Fig.1

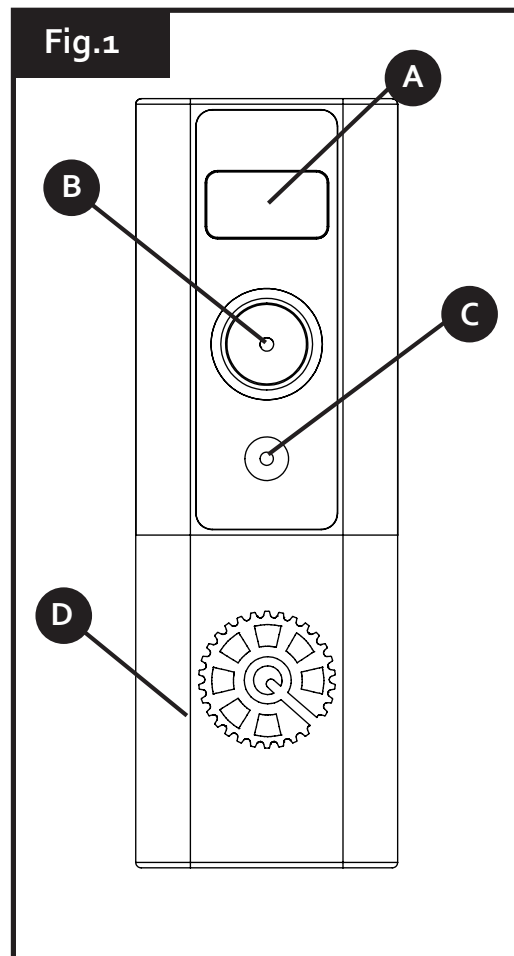

Wiring Diagrams - Two Motor Setup (Single/Twin)

Refer to pages 2 & 3.

Wiring Diagrams - Four Motor Setup (AWD)

Refer to pages 9 & 10.

Fig.A

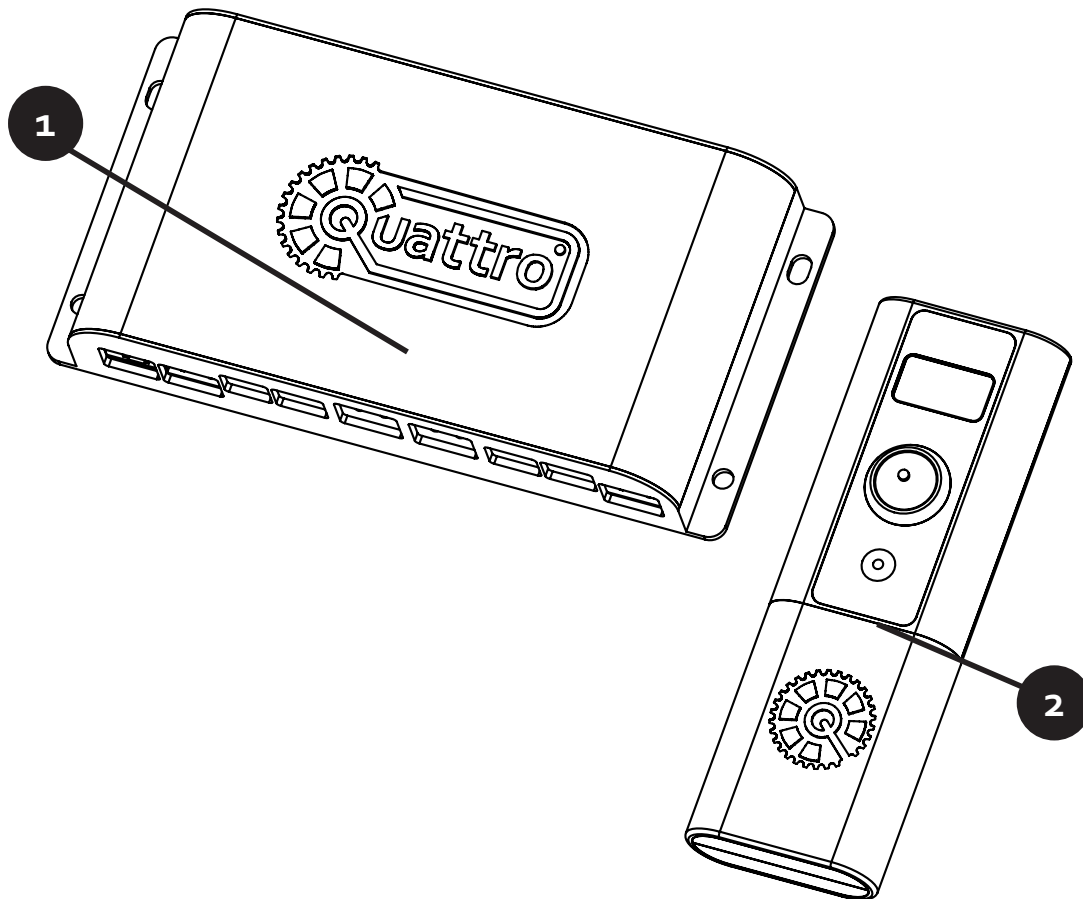

Fig.1

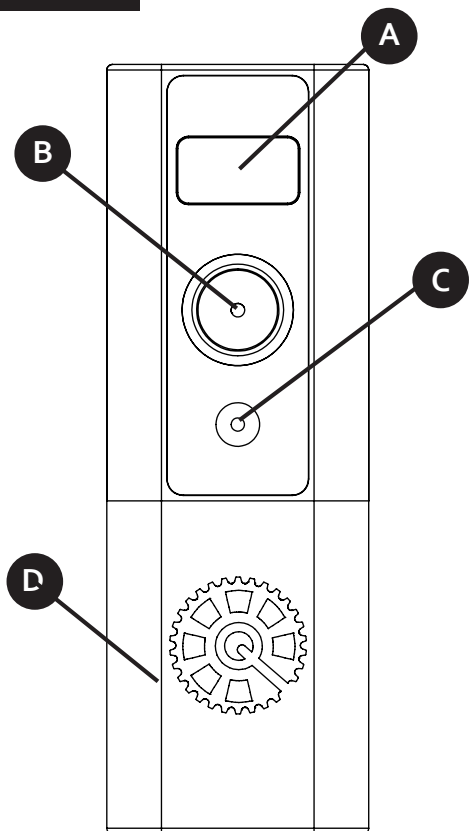

Fig.2

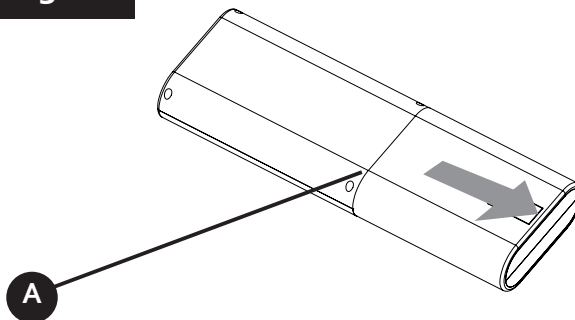

Fig.3

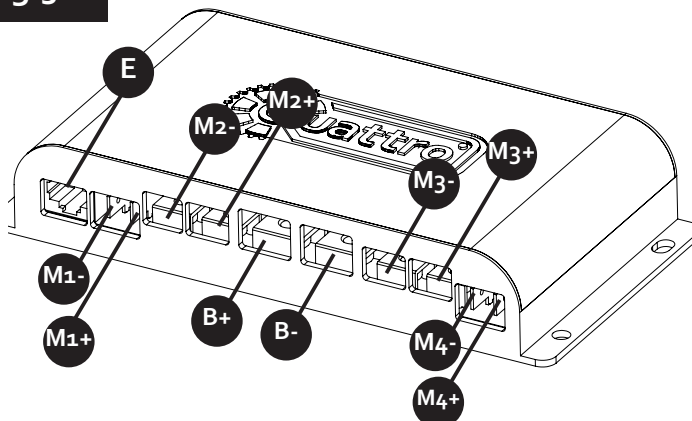

Fig.4

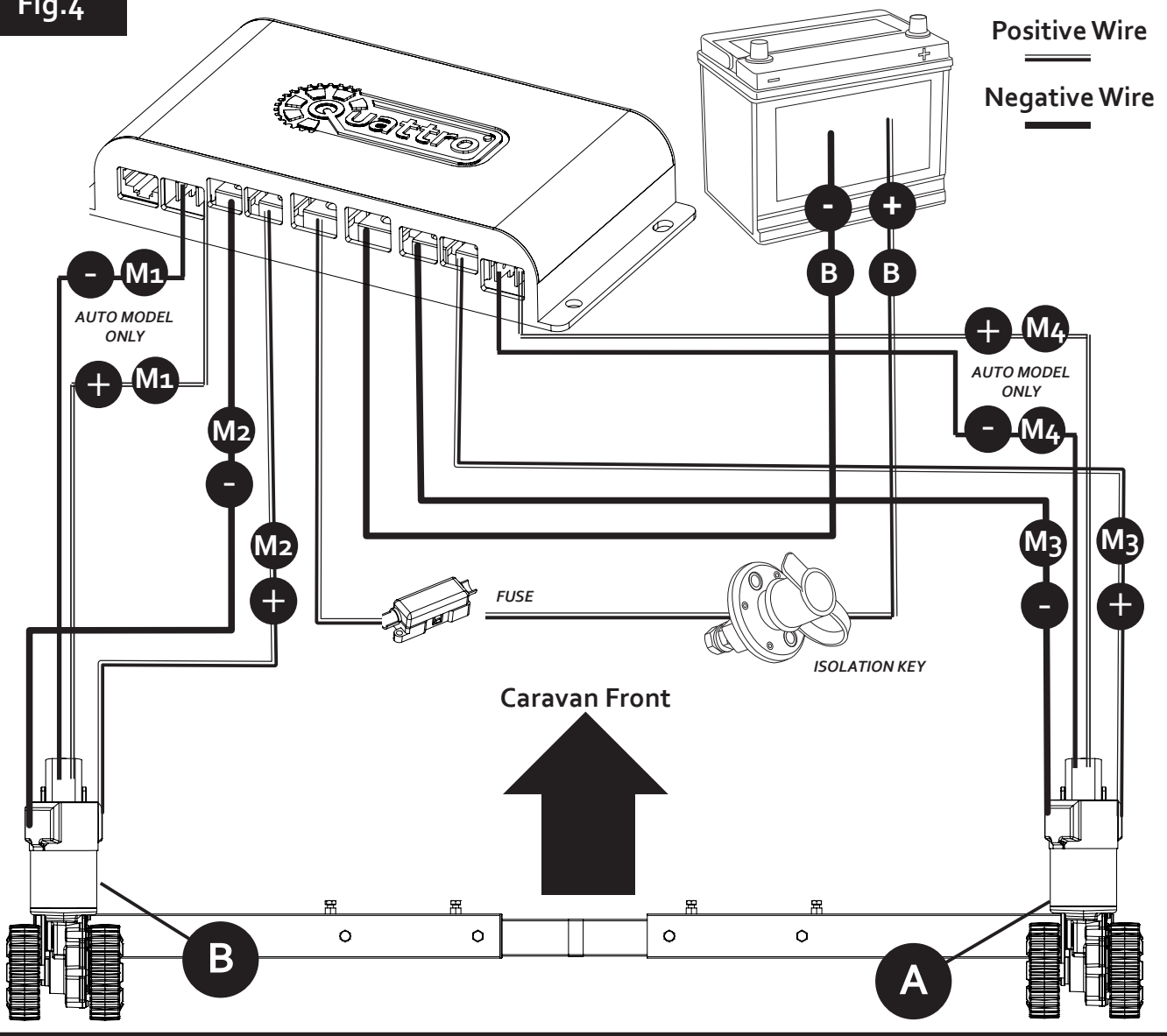

Table of Contents

| | |
|------------------------------------------------------|---------------|
| Installation - Electrical/Electronic Components | Page 3 |
| Operation Safety Guidelines | Page 4 |
| Operation - First Use | Pages 4/5 |
| Operation - Remote Control Handset First Use | Page 5 |
| Operation - Setup & Handset Pairing | Page 6 |
| Operation - Manoeuvring | Page 6 |
| Operation - Mover Engagement/Disengagement | Page 7 |
| Operation - Shutdown Procedure & Battery Replacement | Page 7 |
| Troubleshooting | Pages 7/8 |
| AWD - Setup & Wiring | Pages 9,10,11 |
| Product Registration & Guarantee | Page 12 |

Package Contents (Fig.A)

| Ref | Qty | Description | Ref | Qty | Description |
|-----|-----|------------------------|-----|-----|------------------------------------------------------|
| 1 | 1 | Electronic Control Box | 3 | 2 | AA type 1.5V Batteries (not illustrated) |
| 2 | 1 | Remote Control Handset | 4 | 1 | Link Cable (not illustrated ¹ - AWD only) |

Installation - Electrical/Electronic Components

FOR PART NUMBER REFERENCES WITHIN THIS MANUAL REFER TO **FIGURE A** IN THE MAIN INSTALLATION MANUAL.

Make sure the 12V supply from the battery and any 230V electricity supply are disconnected.

Find a suitable place for the Electronic Control Unit (1), such as a storage area, under a seat or a bed. Make sure this place is dry and close to the battery (30cm to 60cm). The unit can be mounted on the bottom (horizontal) or on the wall (vertical). When choosing location, ensure that the unit cannot easily be damaged.

Fix the Electronic Control Unit(s) securely into position with four screws (19). Note: if the provided screws are not of suitable length or type for the desired location/material please substitute these as appropriate. For an AWD installation connect the link cable between control box ports E (Fig.3).

Drill a 25mm hole through the floor of the caravan approximately 150mm centrally in the front of the control unit (1) terminals.
Caution! Take extra care to avoid any chassis members, gas pipes and electrical wires!

To wire motors locate the terminals on motor portions - these can be identified from the Installation Manual. Please also refer to Fig.4 - attach positive wire (red) to terminal marked in red on each mover (Fig.4 - 3 & 1). Attach negative wire (black) to remaining terminal on each motor (Fig.4 - 4 & 2).

Route the motor-cables in accordance with wiring diagram (Fig.4) (red = positive, black = negative).

Keep all motor cables an equal length, so it is advised that each pair of cables is routed towards the centre line of the caravan's length and then onward to the drilled hole near the Control Unit (1). With a 2 motor system, on heavier caravans you may need to upgrade to our thicker gauge wiring to maintain maximum performance on steep inclines or curbs.

The wiring diagram (Fig.4 + Table.A (see below) depicts the wiring route when installing the motor units in FRONT of the wheels/ axle towards the 'A' frame. Please refer to Table.B (below) for installation of the motor units to the REAR of the axle. Note: If you are fitting two sets of motors onto a twin-axle caravan to form a AWD Quattro system refer to the wiring diagrams on pages 9 & 10 of this manual to ensure rear axle is correctly wired.

Table . A SINGLE AXLE - FRONT AXLE FITTING

Motor A Positive (+) cable to terminal M3+
Motor A Negative (-) cable to terminal M3-
Motor B Positive (+) cable to terminal M2+
Motor B Negative (-) cable to terminal M2-

Table . B SINGLE AXLE - REAR AXLE FITTING

Motor A Positive (+) cable to terminal M2-
Motor A Negative (-) cable to terminal M2+
Motor B Positive (+) cable to terminal M3-
Motor B Negative (-) cable to terminal M3+

Mark the ends of the Motor Cables (12 & 13) for both motor units using the cable markers (25). The cables for the left and the right motor should have the same length. Avoid any loops.

Route the motor cables along the underside of the caravan floor, inside the supplied Cable Trunking (11) (this will protect the electrical cables against sharp edges and dirt) through the drilled hole. Also use a combination of the smaller P-clips (21) where appropriate.

Secure the Cable Trunking (11) to the chassis or under body of the caravan by using the P-clips (20) and screws (19). Once the motor cables are through the drilled hole next to the Control Unit (1), cut the cables, ensuring that they are the same length. Remove approx 5mm of the insulation for the ends. Fix the spade connectors (24) by using crimping pliers. A secure and good quality connection on each cable is essential.

Attach the connectors to the terminals on the Control Unit (1) (see wiring diagram Fig.20).

Route the Battery Cables (14 & 15) from the battery to the Control Unit (1).

 **The in-line fuse/s must be installed between the positive battery cable/s that connect the battery and the control unit. On a AWD system two fuses are required (one per battery wire). For heavier caravans thicker gauge wiring may also be recommended to ensure maximum performance. Please consult your dealer for further details if necessary.**

The Power Isolation Switch (29) will also need to be installed in-line between the Control Unit and the battery, so please plan where this will be located. If available. This switch must not be installed in the same sealed area as the battery, but may be installed in an adjacent separately sealed area, usually there is a space to the side of the battery near the mains power connection.

Install the Isolation Switch (29) between the battery and the Control Unit on the positive (+) cable, use two of the 8mm Battery Terminal Connectors (22) to link the cable to the switch terminals. Nuts and bolts are provided to mount the switch but please substitute as necessary if they are not of a suitable type. Again, it is recommended to use the supplied Trunking (11) to protect the cables against sharp edges. Attach the trunking with P-Clips (20) and P-Clip Screws (19).













Connect the Battery Cables to the existing battery terminals (red = positive, black = negative). Two types of Battery Terminal Connector (22 & 23) are provided for use as appropriate.

 **Caution!** Make sure that you do not reverse the Positive (+) and Negative (-) connections. Incorrect connection (reverse polarity) will result in damage to the control box.

The length of wiring from one motor and the other must always remain the same, this will prevent a performance difference (due to voltage drops) from one side to the other. Fix the spade connectors using crimping pliers. A secure and good quality connection on each cable is essential.

Finally, connect the Battery Cables (14 & 15) to the Control Unit (1). Installation of your Caravan Mover is now complete.

Operation - Safety Guidelines

-  Before use, always check the mover for any damage.
-  When towing or moving the caravan please be aware, at all times, that ground clearance is reduced by 50mm when the Mover has been fitted.
-  To maintain signal strength, always ensure that during manoeuvring the distance between the remote control and the caravan does not exceed 5 metres.
-  DO be aware that the mover increases your caravan or trailer weight. So this reduces the payload of the caravan.
-  DO always make sure that the rollers are fully disengaged from the tyres when the mover is not in use. This is better for the tyres and for the mover.
-  DO always make sure that the rollers are fully disengaged before towing/moving the caravan by vehicle or manpower. This can damage the tyres, mover and the towing vehicle.
-  DO always make sure that after you have finished using the Mover, the Battery Power Isolation Switch (29) is switched off and the key is removed and stored in a safe place (out of reach of children or other unauthorised people).
-  DO always make sure that the remote control is stored in a safe place (out of reach of children or other unauthorised people).
-  DO always apply the handbrake after manoeuvring, before disengaging the drive rollers from the tyres.
-  DO always ensure that children and pets are kept well out of the way during operation.
-  DO NOT rely on the mover to act as a brake.
-  DO NOT exceed the total Safe Working Load (SWL).
-  DO NOT make any modifications on the caravan mover (mechanical or electronically). This can be very dangerous! No warranty claim will be accepted and we cannot guarantee the function of the mover if any modifications are made. We will not be liable for any damage whatsoever caused as a result of incorrect installation, operation or modification.

Operation - First Use

The mover has two Motor Units (Installation Manual 1 & 2). In general they are mounted in front of the axle of the caravan/trailer. Both units are identical, so either can be fitted to nearside or offside framework. Please refer to appropriate installation manual that is packaged in with your mover framework.

(Fig.2 - Installation Manual)

- A: Drive Roller
- B: 12V Motor
- C: Connection Terminals (+ and -)
- D: Base Unit
- E: Drive Unit
- F: Gear Housing

 **Always ensure that you are close enough to engage the caravan's handbrake when manoeuvring on uneven terrain and gradients/slopes in case of mechanical failure. Do not use the mover as a brake, when you have finished manoeuvring always engage the caravan's handbrake, and disengage the movers when not in use.**

 **SAFETY FIRST! Ensure that there are no persons or obstructions in the vicinity of the caravan prior to testing.**

 Please make sure you read the safety instructions very carefully and make sure that you follow these guidelines!

 Make sure that the battery that supplies the mover is fully charged and in good condition.

 Make sure that the caravan is free from the vehicle and the handbrake is on. Also make sure that the corner-steady feet are fully raised.

Engage both rollers as described in 'Operation-Mover engagement'. For the manual engagement movers this only needs to be done on one side of your caravan since the other side will automatically follow via the cross actuation bar.

Turn on the Battery Power Isolation Switch (29).

Before operating the Mover, release the handbrake.

Store remote control in a safe place (out of reach of children or other unauthorised people).

Operation - Remote Control Handset First Use

The Remote Control handset (2) is powered by two 'AA' 1.5V batteries (refrain from using lower voltage rechargables), and is activated by double-pressing the button (Fig.1C). Once activated the display will illuminate. If the handset has not been used 60 seconds it will power off. Ensure before continuing that the control unit has power by turning on your isolation key.

Fig.1
A = Handset display
B = Directional thumb stick
C = Multi-function button

After the handset has completed powering on the following home screen will shown on screen. Note if any icons are flashing this indicates an issue, or that the handset hasn't connected to the control box. Ensure isolation key is turned on before powering on the handset, and allow up to 10 seconds for a connection to be established.



(A) Signal strength - Indicates signal strength between handset and control unit inside the caravan.

(B) System status - If a smiling face is showing the system is working correctly.
- If a magnifying glass is showing, the handset is waiting to pair.
- If an 'E' number is showing refer to page 8/9 for error diagnosis.

(C) Handset battery status - Indicates handset battery level.

(D) Leisure battery status - Indicates voltage level of leisure battery, for maximum performance ensure battery is fully charged and showing 4 bars before operating mover.

(E) Mover orientation - This shows the direction of travel of the caravan, when the thumb stick is moved the caravan will follow in this direction. By default the hitch is designated as the forward direction. At any time press the multi-function button (Fig.1C) to flip the caravan orientation, the rear of the caravan will then move forward when the thumb stick is moved upwards.

*Caravan orientation flipped &
Handset searching for signal*

Operation - Setup & Handset Pairing

By default the Quattro system is set up for use with a Quattro 600 Auto mover on a single axle caravan. If a Quattro 500 manual mover is being used or if the system is fitted to a twin axle caravan, the settings must be changed on the handset.

The Quattro handset has a settings menu which allows the user to pair their handset or change operating modes. With the handset powered on, firmly press on the centre of the thumb control button (Fig.1B) and multifunctional button (Fig.1C) for three seconds, this will open the system menu. Navigate through the system menu moving the thumb control (Fig.1B) up or down. Select the settings icon (gear) by pressing the thumb control button (Fig.1B) firmly. Once the settings menu is entered, move the thumb control up and down to desired function. At any point, press multifunctional button (Fig.1C) to go back to previous screen, or hold for two seconds to return to home screen.

To navigate between settings functions move the thumb control up or down, and press thumb control (Fig.1B) down firmly to make a selection. To change a setting move the thumb control (Fig.1B) right or left and press thumb control (Fig.1B) down firmly to make a selection. The active option will be shown with a solid white circle in the centre of the icon.



Handset Pairing - The handset and control box will arrive pre-paired so this setting is only required when the handset has lost its pairing or a replacement part has been received. To pair the handset press thumb control button (Fig.1B) when this icon is displayed in the menu to begin the pairing search process. Ensure the caravan power is on and hold the handset within 10cm of control box. Once successfully paired the handset will return to the home screen.

Axle Mode Selection - By default Quattro systems are set to work in single axle mode, if installed as a twin axle or AWD system this setting should be changed to suit.



Single Axle Mode
For use with single axle caravans, all functions including spin on the spot are enabled.



Twin Axle Mode
For use on twin axle caravans (2 motors). Spin on spot function disabled.



AWD Mode
For use on twin axle caravans (4 motors). Spin on spot function disabled.

Mover Model Selection - By default Quattro electronics are set to Quattro Diamond Mode. If a different mover is installed, this setting should be changed to suit. Note: Selecting the wrong setting for your mover could risk damage to the unit or your tyre, or the system not working.



Quattro Diamond
For use with the Quattro Diamond (Quattro600 Auto mover) only.



Quattro Platinum
For use with the Quattro Platinum (EGO500 Auto Mover) only.



Quattro Manual
For use with Quattro movers with a manual (Tool) engagement.

Operation - Manoeuvring

The Quattro mover utilises a thumb control for precise control of speed and direction. The speed of operation is dictated by how far the stick moves from its centre point, to the outer perimeter. Direction is dictated by the radial position of the thumb stick (moving the stick from left to right).

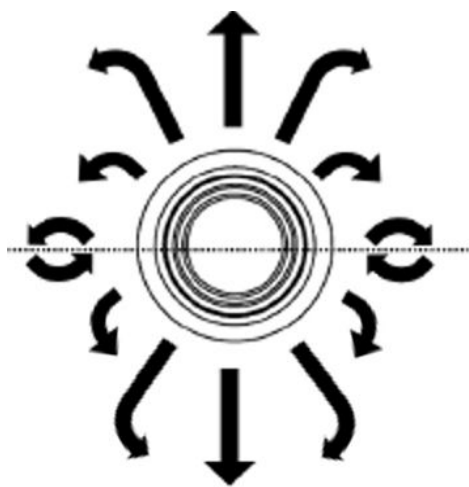

Refer to your handset screen to ensure the caravan is orientated in the desired way. For example if the hitch is at the top of the display, when the thumb control is moved upwards the hitch side of the caravan will move forward. If the rear of the caravan is at the top of the display, the rear of the caravan will move forward when the thumb control is moved upwards.

For smooth operation always begin by moving the thumb control in the general direction you would like to head (forwards or reverse), the further the thumb control moves away from the centre the faster the mover will operate. From this point progressively move the control radially (sideways) to achieve a fluid change in direction. The more the control is moved sideways the tighter the turning radius that will be achieved. Note moving the thumb control to the hard right or left position will engage the spin on the spot function on single axle caravans.

Single axle caravans have the ability to spin on the spot. To engage this, move the stick into the hard right or hard left position from centre.



The Quattro electronics have a regenerative braking feature that allows full directional control to be maintained while moving downhill. This is achieved by feeding energy under braking back from the motors into the battery. Some lithium leisure batteries do not allow this and when an incompatible battery is detected, the feature will be automatically disabled within software to prevent damage. Therefore, when moving down an incline with an unsupported battery, manoeuvring is limited. To ensure the best performance and compatibility on a lithium battery we recommend only using approved batteries.

Operation - Mover Engagement/Disengagement

Always ensure your caravan handbrake is on before engaging or disengaging the mover system to prevent unwanted movement of the caravan. Only release the handbrake when the mover is securely engaged to the tyre and you are ready to move the caravan.

 Automatic Engagement - During transit/installation the engagement motor end block may rotate causing it to tighten. Before first use, place the manual engagement tool in the rear of the engagement end block (removing rubber cap) and turn the tool clockwise to ensure it is moving freely, there should be little resistance required to turn the tool.

Turn on the handset and then from the home screen hold the multifunctional button (Fig.1C) for 3 seconds to engage or disengage the mover. When engaging/disengaging the following information will be shown on the display (image varies based on mode):



Mover disengaging, press button (Fig.1C) to stop at any point.



Mover engaging, press button (Fig.1C) to stop at any point.

Once engagement is completed the handset will return to the home screen and thumbstick controls will be activated allowing the caravan to be moved. In the event of an issue, a manual engagement hex T bar is supplied that can be used to engage/disengage. To use this remove the small rubber plug on the rear of the engagement motor and turn the engagement worm manually.

Manual Engagement - In order to engage the rollers, fit the end socket of the Engagement Tool (6) on the spindle (Fig.2G & Fig.4A of installation manual) on the right or left drive unit.

Position the engagement tool parallel to the ground, then rotate the tool through approximately 180 degrees. Note: to engage the rollers you always rotate the tool towards the tyre, irrespective of which side you are operating the engagement from.

The engagement mechanism utilises a simple over-centre cam that pushes the rollers onto the tyres and then locks into place automatically. If the mover has been installed correctly, at exactly 20mm away from the tyres when disengaged, the amount of force provided onto the tyre by the roller will be sufficient for most circumstances of use (Fig.6 of installation manual).

To disengage the rollers, simply refit the tool onto one of the spindles and rotate away from the tyre. Please note that you will feel a small amount of resistance initially as you disengage the cam from its locked position; the spring will then do the rest of the work and pull the roller away from the tyre and into the fully disengaged position (Fig.5 of installation manual).

Operation - Shutdown procedure & battery replacement

Turn off isolation key to cut power to the Quattro control box. To turn off the handset double-press multifunctional button (Fig.1C) twice.



Changing batteries in the remote control:

Open the rear cover of the handset by pushing gently and sliding the rear cover in the direction of the arrow (Fig.2). Take out the depleted/old batteries and dispose in the appropriate way (check with your local authority for correct disposal of batteries). Install new replacement batteries. Make sure to use leak proof batteries (No claims under guarantee can be considered for damage caused by leaking batteries). Slide the rear cover on gently and it will click into place.

Troubleshooting

Unit fails to operate or moves intermittently. Possible solutions are:

Handset not connected - Ensure that all home screen items (Fig.1A) are solid and not flashing. If they are then it is likely that the handset has not yet connected. Move closer to the caravan, if the handset still fails to connect, run through the handset pairing process. Ensure that power is getting to the Quattro control box before beginning the pairing process.

Handset not turning on - Handset battery could be depleted. If empty, renew using two new 'AA' 1.5V batteries.

Caravan battery could be empty - Check that the leisure battery is fully charged. Refer to handset display (Fig.1A)

Caravan battery could be low - with the rollers engaged. Ensure that when operating the mover that the leisure battery icon on display (Fig.1A) remains at least 3 bars under load. If the charge indicator is dropping to 2 or below it may indicate a depleted or damaged battery.

Electronics current limit reached - Allow the mover to sit for 30 seconds, this will allow the electronics to restart and operation will begin again. If the problem persists call your Quattro mover supplier.

Motor cable issue - Check all connections between motor cables and control unit.

Battery cable issue - Check battery terminals, clean and connect again.

Low signal - before operating the mover ensure that the signal between the control box and handset is good. Refer to handset display (Fig.1A). The mover will operate best with at least 3 bars of signal.

Rollers slip on wheels - Check that the distance of the rollers to the tyres is 20mm on both sides. Check for correct tyre pressure by referring to your caravan manufacturer's handbook. If the pressure is low, the roller would need to be pushed into the tyre further than usual to gain sufficient traction.

Futher Diagnostics - Near the bottom of the system menu there is a diagnostic feature. Press thumb stick button (Fig.1B) to enter this menu. This will overlay the original home screen with useful information that will allow the user/support technician to identify any areas potentially at fault. When calling the technical support team please have this menu open and ready.



Diagnostic settings menu icon.

On the top face of the Quattro control box, under the Quattro logo are two small LED light indicators. If you are having an issue with your mover system, refer to the guide below to help identify the possible fault.

Blue LED

- No light - Control box is not functioning or receiving power.
- Static - Communication system ok, ready to connect.
- Slow flashing - Handset connected.
- Fast flashing - Handset signals received (buttons pressed, or thumbstick moved).

Red LED

Red LED indicating motor driver state in this way:

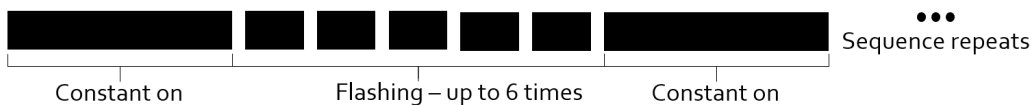

- OFF - Control box has no power or is not functioning correctly.
- Static On - Motor driver system ok, ready to operate.
- Flash 1 time (or fast flashing) - Controller working correctly and driving the motor

| Error Code / Sequence | Description | Possible cause and action |
|-----------------------|------------------------------|-------------------------------------------------------------------------------------------------------------------------------------------------------------------------------------------------------------------------|
| E2 - Two Flashes | Over Current | Usually caused by a very high load on the mover system. - Check the battery is fully charged. - Ensure all wiring and connectors are installed correctly. - Ensure caravan isn't exceeding safe working limit. |
| E3 - Three Flashes | Under Voltage | Usually caused by flat battery. - Charge the battery or check battery voltage. |
| E4 - Four Flashes | Over Voltage | Usually caused by incompatible battery, or if battery is charging while mover in use. - Check battery type or unplug charger. |
| E5 - Five Flashes | Over Temperature | Usually caused by prolonged use on heavy load. - Allow 5 minutes for electronics and motors to cool down. - Split operation (e.g. a long slope) into several short journeys. |
| E6 - Six Flashes | Critical Low Voltage Lockout | Usually caused by loose or dry connection on the wiring, occasionally caused by end-of-life battery. - Check wiring and terminal conditions immediately. - Check battery health using appropriate equipment. |

E2, E3, E4 and E5 error codes will be automatically cleared 4 seconds after the fault is resolved. E6 error codes can only be cleared by cycling power of controller box.

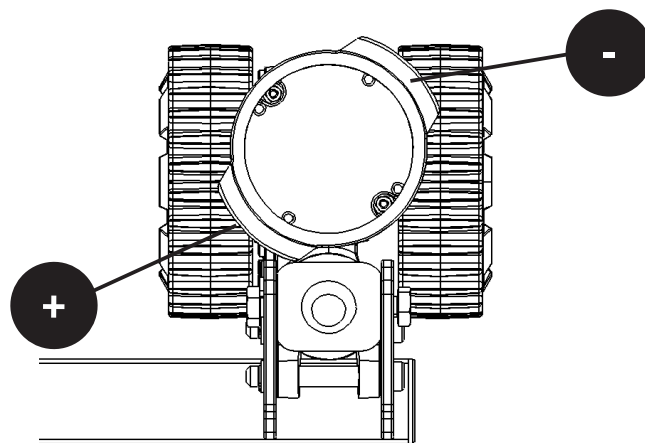
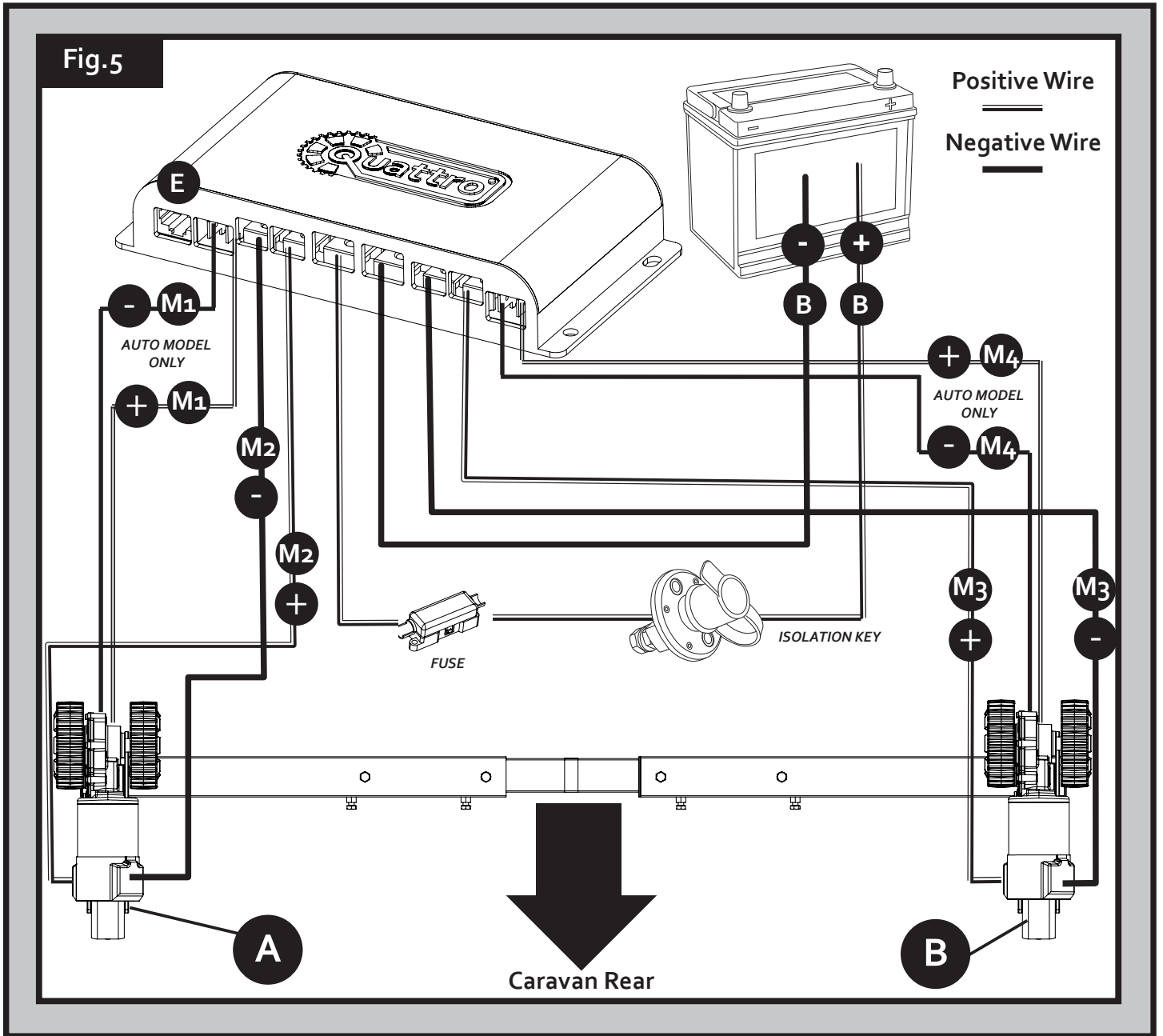

Quattro Diamond: The upper connector on each motor is always negative (black), while the lower is positive (red).

AWD - Setup

Refer to the table below, alongside Fig.4 and Fig.5 to wire the AWD system correctly. Note that if any part of the system is wired incorrectly it could cause damage to the movers or caravan tyres if all rollers do not move in the correct directions.

Table . A AWD - FRONT AXLE FITTING

Motor A Positive (+) cable to terminal M3+
Motor A Negative (-) cable to terminal M3-
Motor B Positive (+) cable to terminal M2+
Motor B Negative (-) cable to terminal M2-

Table . B AWD - REAR AXLE FITTING

Motor A Positive (+) cable to terminal M2+
Motor A Negative (-) cable to terminal M2-
Motor B Positive (+) cable to terminal M3+
Motor B Negative (-) cable to terminal M3-

WARNING: EACH CONTROL BOX MUST BE POWERED INDEPENDENTLY FROM THE BATTERY THROUGH THE SAME ISOLATION SWITCH (TWO POSITIVE AND TWO NEGATIVE WIRES). CONNECTING THE BOXES DIRECTLY (PIGGY BACKING) COULD OVERLOAD/DAMAGE THE SYSTEM. BEFORE TURNING ON THE ISOLATION KEY ENSURE THAT BOTH NEGATIVE CABLES ARE CONNECTED TO THEIR RESPECTIVE CONTROL BOX, FAILURE TO DO THIS WILL ALSO CAUSE DAMAGE TO ONE/BOTH BOXES.

1. Ensure that the motors are disengaged from the caravan wheels. Wire mover system as per tables above referring to Fig.4 and Fig.5.
2. Ensure the link cable is connected into port E on both control boxes.
3. Turn on the isolation switch to supply power to both control boxes.
4. Press button Fig.6A located on the slave control box that is powering the rear axle.
5. Power on handset by double-pressing button Fig.1C on the handset.
6. Set the handset to AWD mode by referring to the "setup and pairing" section on page 6.
7. If required, pair the handset by referring to the "setup and pairing" section on page 6. Before the AWD system will function both the handset and control box will need to be reset.
8. Power off the handset by double-pressing button Fig.1C on the handset.
9. Turn off the caravan isolation key to cut power to the mover.
10. Power on system and handset and ensure that all wheels are rotating in the correct direction, installation is now complete.

Fig.6A

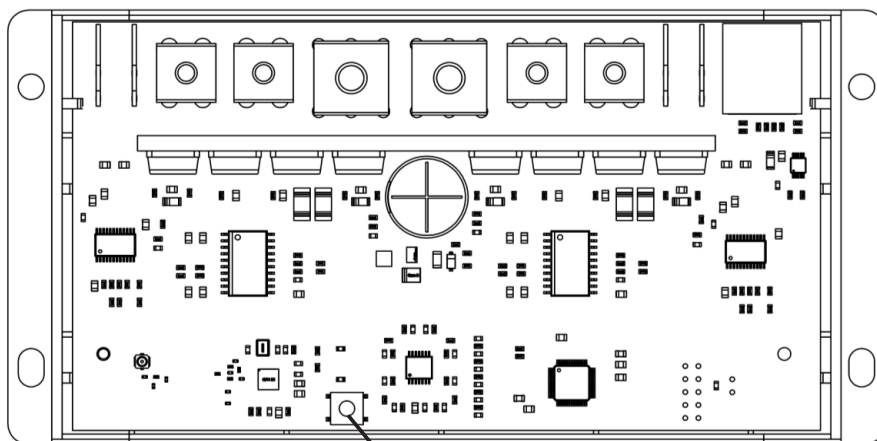

Push this button on the rear-axle slave control box.
Note: The Blue LED will turn off once activated.

Product Registration & Guarantee

Please register your Quattro® caravan mover online within 14 days of purchase to benefit from our 7 year warranty. Registration is quick and simple, go to www.purpleline.co.uk/product-registration. Please retain your original purchase receipt.

Please fill in the Serial Numbers + additional information and retain this manual for future reference.

The serial numbers can be found on the product label of each of the motor sections. The serial number starts with a W- and can be up to 18 digits long. Please make a note of your serial numbers in the section below for future reference. **The serial numbers will be required for product registration.**

| | | | | | | | | | | | | | | | | | | | | | | | | | | | | | | | | | | | | | |
|-----------------------------------------|-------------------------------------------------------------------------------------------------------------------------------------------------------------------------------------------------------------------------------------------------------------------------------------------------------------------------------------------------------------------------------------------------------------------------------------------------------------------------------------------------------------------------------------------------------------------------------------------------------------------------------------------------------------------------------------------------------------------------------------------------------------------------------------------------------------------------------------------------------------------------------------------------------------------------------------------------------------------------------------------------------------------------------------------------------------------------------------------------------------------------------------------------------------------------------------------------|---|--|--|--|--|--|--|--|--|--|--|--|--|--|--|--|--|--|---|--|--|--|--|--|--|--|--|--|--|--|--|--|--|--|--|--|
| Serial No. QUATTRO500/ QUATTRO600 | <table border="1" style="width: 100%; border-collapse: collapse;"> <tr> <td style="width: 5%; text-align: center;">W</td> <td style="width: 5%;"></td><td style="width: 5%;"></td><td style="width: 5%;"></td><td style="width: 5%;"></td><td style="width: 5%;"></td><td style="width: 5%;"></td><td style="width: 5%;"></td><td style="width: 5%;"></td><td style="width: 5%;"></td><td style="width: 5%;"></td><td style="width: 5%;"></td><td style="width: 5%;"></td><td style="width: 5%;"></td><td style="width: 5%;"></td><td style="width: 5%;"></td><td style="width: 5%;"></td><td style="width: 5%;"></td> </tr> <tr> <td style="width: 5%; text-align: center;">W</td> <td style="width: 5%;"></td><td style="width: 5%;"></td><td style="width: 5%;"></td><td style="width: 5%;"></td><td style="width: 5%;"></td><td style="width: 5%;"></td><td style="width: 5%;"></td><td style="width: 5%;"></td><td style="width: 5%;"></td><td style="width: 5%;"></td><td style="width: 5%;"></td><td style="width: 5%;"></td><td style="width: 5%;"></td><td style="width: 5%;"></td><td style="width: 5%;"></td><td style="width: 5%;"></td><td style="width: 5%;"></td> </tr> </table> | W | | | | | | | | | | | | | | | | | | W | | | | | | | | | | | | | | | | | |
| W | | | | | | | | | | | | | | | | | | | | | | | | | | | | | | | | | | | | | |
| W | | | | | | | | | | | | | | | | | | | | | | | | | | | | | | | | | | | | | |
| Date of Purchase | | | | | | | | | | | | | | | | | | | | | | | | | | | | | | | | | | | | | |
| Name of Dealer | | | | | | | | | | | | | | | | | | | | | | | | | | | | | | | | | | | | | |

Quattro® caravan mover systems are provided with a UK parts only warranty for a period of 7-years which includes the first 12 months statutory, plus an additional 6 years extended warranty. Please note that the extended 6 year warranty is only offered if Product Registration is completed and returned within 14 days from the date of purchase. Any warranty claims must be directed through the place of purchase with a proof of purchase provided. Warranty cover is limited to products within UK mainland only. Warranty not transferrable past first owner.

Notes



Purple Line Ltd, Unit 1,
Peninsula Business Centre,
Wherstead,
Suffolk
IP92BB

Web: www.quattromover.com

Tel: +44 (0)1473 601200

Email: info@purpleline.co.uk